

ATOM DX™ miniature encoder system

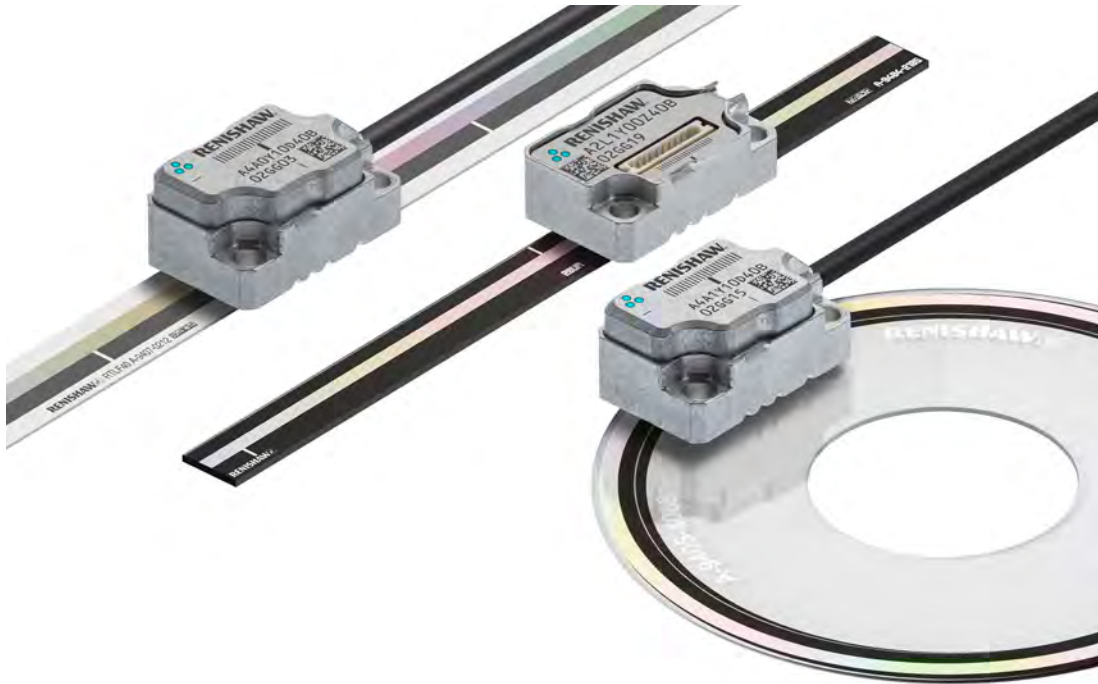

The ATOM DX™ encoder series is Renishaw's smallest incremental optical encoder with digital output direct from the readhead, providing positional feedback, onboard interpolation, and filtering optics all in a miniature package.

ATOM DX incorporates the market proven filtering optical system of the ATOM™ encoder series, and integrates Renishaw's high-performance interpolation technology, reducing system size and removing the need for additional adaptors and interfaces. This makes ATOM DX suitable for the most space constrained applications where performance cannot be compromised.

Constructed with Renishaw's integrated set-up LED for an intuitive and simple installation process based on the well-established auto-calibration routine, ATOM DX is ready to install straight from the box. It is compatible with the optional ADTi-100 Advanced Diagnostic Tool and ADT View software to give in-depth advanced diagnostic information to aid optimisation of encoder installation and in-field fault finding to satisfy the most demanding motion control applications.

ATOM DX can be used with the ATOM series of linear, partial arc and rotary scales to meet most application requirements.

- Miniature, all-in-one, digital output optical encoder with resolutions down to 2.5 nm
- Class leading signal stability and dirt immunity due to filtering optics
- Long-term stability provided by integral Auto Gain Control (AGC) and Auto Offset Control (AOC)
- Low sub-divisional error (SDE) and jitter
- Integrated set-up LED for ease of installation
- Maximum speed up to 20 m/s (3.63 m/s @ 0.1 µm resolution)
- Available in 20 µm and 40 µm scale pitch versions
- Range of high accuracy linear, partial arc and rotary scales with auto-phase bi-directional optical reference mark
- Optional Advanced Diagnostic Tool ADTi-100 to optimize set-up and assist with system diagnostics
- Available in two variants; cabled and top exit, for the most demanding space constrained installations

www.renishaw.com/atomdxdownloads

#renishaw

System features

High performance

- **Performance in speed**

ATOM DX encoders offer maximum speeds up to 20 m/s and a range of high-speed interpolation options.

- **Performance in scale**

ATOM DX offers linear tape scales with specified overall accuracy to $\pm 5 \mu\text{m/m}$ @20 °C, reducing the need for 2-point compensation.

- **Performance in velocity control**

ATOM DX incorporates Renishaw's latest interpolation technology with updated signal processing algorithms to reduce sub-divisional error (SDE). This helps to reduce velocity ripple and improve closed loop feedback in motion control systems.

- **Performance in a miniature head**

ATOM DX fits in to the smallest applications with heights as low as 7.85 mm. The top exit variant offers all the benefits and features of the cabled ATOM DX encoder, but in an even smaller package. The top exit variant is a component encoder with the cable assembly integrated separately to the readhead, making the ATOM DX top exit suitable for the smallest spaces.

- **Performance over contamination**

ATOM DX features the proven filtering optics of the ATOM encoder range. This optical scheme is tuned to a specific spatial frequency, so it rejects other harmonics, including those caused by dirt or other contaminants. The result is a Lissajous with high purity, that retains its fidelity even when the scale is exposed to contamination: ideal for applications where reliability is critical.

Optional Advanced Diagnostic Tool ADTi-100



The ATOM DX encoder system is compatible with the Advanced Diagnostic Tool ADTi-100 and ADT View software, which provides comprehensive real-time encoder data feedback to aid more challenging installations and diagnostics. The intuitive software interface can be used for:

- Remote calibration
- Signal optimization over the entire axis length
- Reference mark indication
- Digital readout of encoder position (relative to scale)
- Monitoring velocity
- Exporting and saving data

Compatible scales

- **Stainless-steel tape scale (RKLF):**

Self-adhesive mounted stainless steel tape scales that can be wrapped around drums, arcs or shafts with radii down to 26 mm.

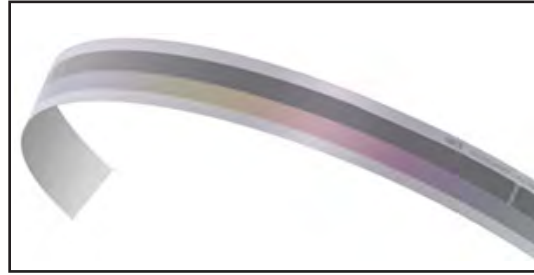

- **Stainless-steel tape scale (RTLFL):**

High-accuracy scales with graduations directly marked onto the steel tape surface. Available on reels for cut-to-length convenience.



- **Glass linear spars (RCLC):**

Conventional glass spars, available in lengths up to 130 mm.



- **Stainless-steel discs (CENTRUM™ CSF40):**

Self-centring rotary scales that are quick and easy to install.



- **Glass discs (RCDM):**

High-accuracy rotary scales with outer diameters down to 17 mm.



ATOM DX cabled readhead dimensions

Dimensions and tolerances in mm

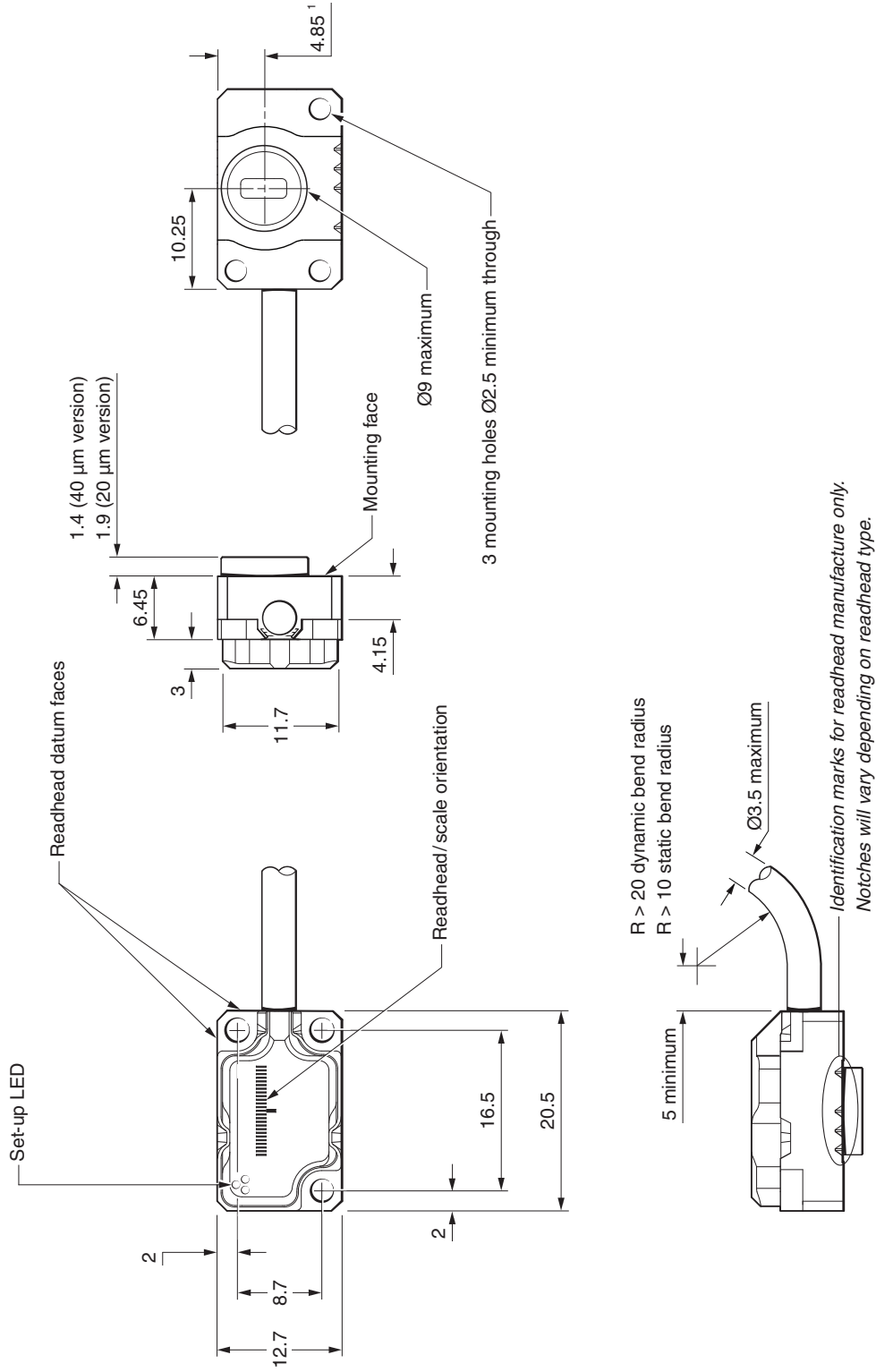

¹ Not the optical centreline.

ATOM DX top exit readhead dimensions

Dimensions and tolerances in mm

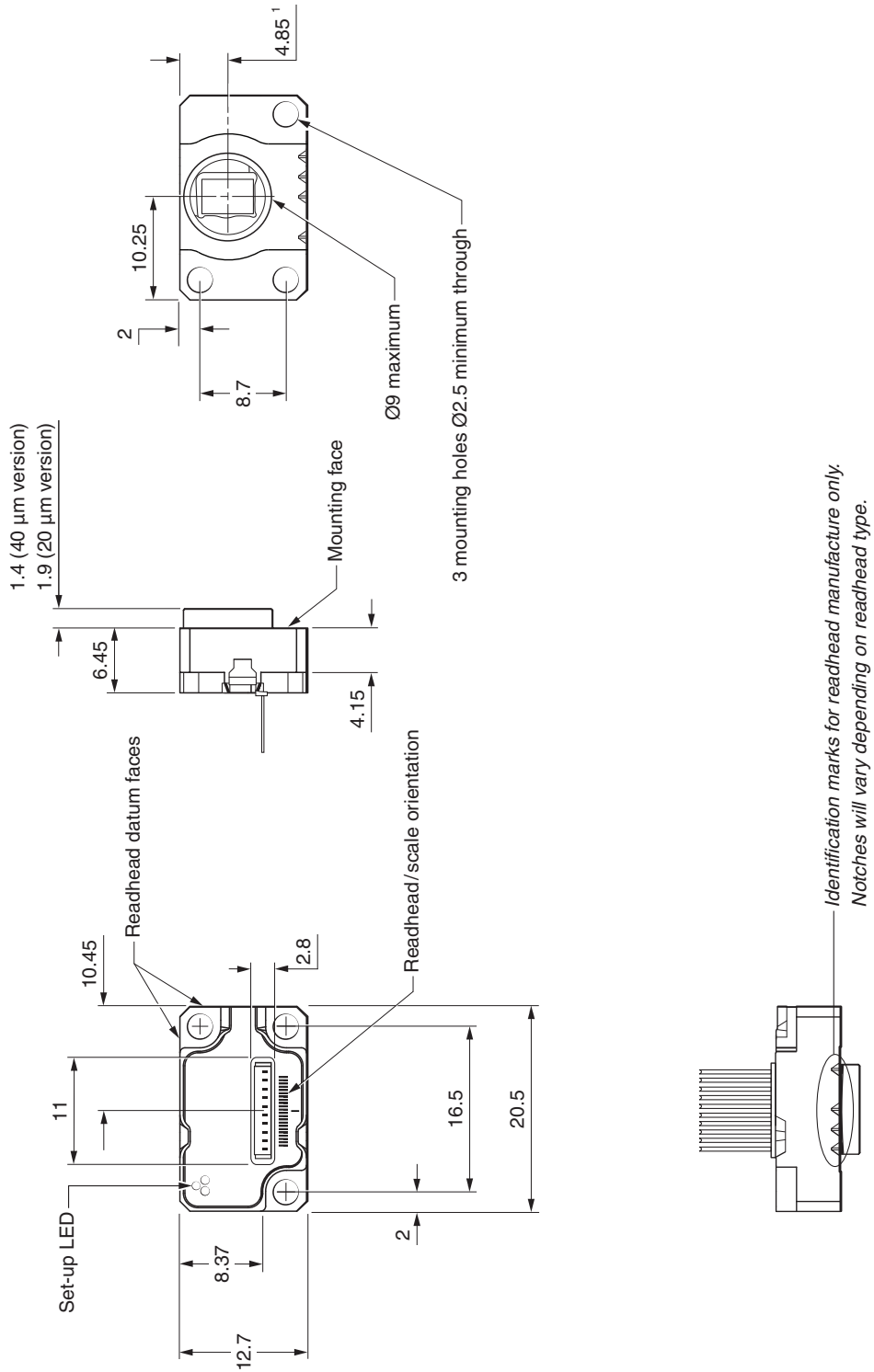

¹ Not the optical centreline.

General specifications

Power supply	5 V $-5 / +10\%$	Typically < 200 mA fully terminated Power from a 5 Vdc supply complying with the requirements for SELV of standard IEC 60950-1
	Ripple	200 mVpp maximum @ frequency up to 500 kHz
Temperature	Storage	$-20\text{ }^{\circ}\text{C}$ to $+70\text{ }^{\circ}\text{C}$
	Operating	$0\text{ }^{\circ}\text{C}$ to $+70\text{ }^{\circ}\text{C}$
Humidity		95% relative humidity (non-condensing) to IEC 60068-2-78
Sealing		IP40
Acceleration (system) ¹	Operating	400 m/s ² , 3 axes
Shock (system)	Operating	500 m/s ² , 11 ms, ½ sine, 3 axes
Vibration	Operating	100 m/s ² max @ 55 Hz to 2000 Hz, 3 axes
Mass	Cabled readhead	3.2 g
	Top exit readhead	2.9 g
	Cable	18 g/m
EMC compliance		IEC 61326-1 (cabled readhead variant only)
Cable	Cabled readhead	10 core, high flex, EMI screened cable, outside diameter 3.5 mm maximum Flex life > 20×10^6 cycles at 20 mm bend radius, maximum length 3 m (Extension cable up to 25 m when using Renishaw approved extension cable) UL recognised component 
	Top exit readhead	Cables available in lengths from 0.5 m to 3 m with 15-way D-type or 10-way JST (SH) connector options
Connector options	Cabled readhead	9-way D-type 15-way D-type (standard and alternative pin-out) 10-way JST (SH)
	Top exit readhead	10-way JST (SUR)
Typical sub-divisional error (SDE)	20 μm version	< $\pm 75\text{ nm}$
	40 μm version	< $\pm 120\text{ nm}$

¹ Bolted CENTRUM CSF40 acceleration: 100 m/s² radial, 50 m/s² axial

RKLF tape scale installation drawing

Dimensions and tolerances in mm

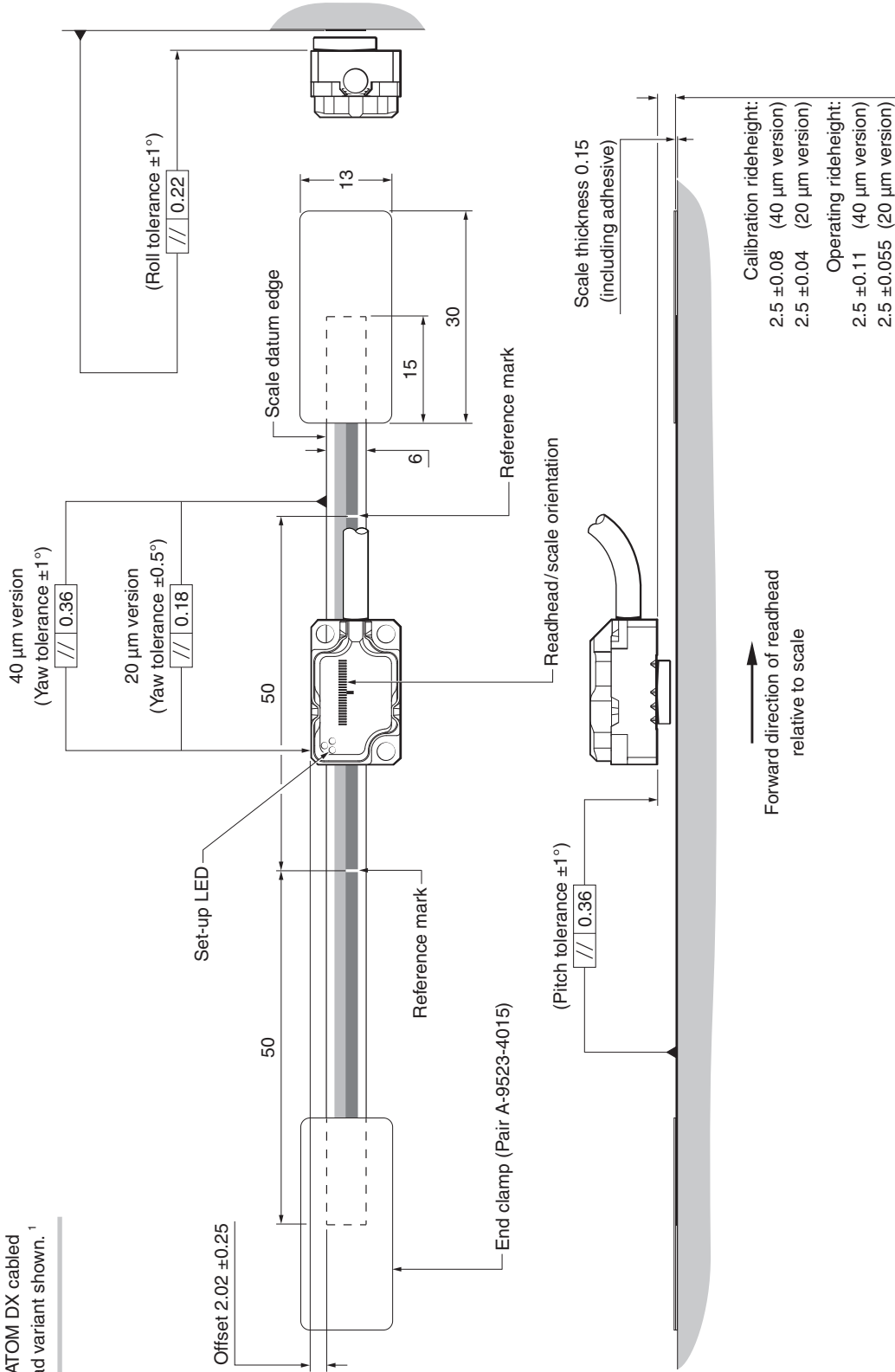

NOTE: ATOM DX cabled readhead variant shown.¹

For further information on the use of RKLF scale for partial arc applications, refer to the *RKL partial arc scale* data sheet (Renishaw part no. L-9517-9897).

¹ For readhead dimensions see pages 4 and 5.

RKLF tape scale technical specifications

Material		Hardened and tempered martensitic stainless steel fitted with a self-adhesive backing tape
Form (height x width)		0.15 mm x 6 mm (including adhesive)
Scale pitch ¹		20 µm and 40 µm
Reference mark		Auto-phase optical reference mark repeatable to unit of resolution throughout specified speed and temperature range Customer de-selectable reference marks at 50 mm spacing ² Reference mark in the centre of scale for lengths < 100 mm
Accuracy (at 20 °C)	RKLF20-S/RKLF40H-S RKLF40-S	±5 µm/m ±15 µm/m
Linearity (at 20 °C)	RKLF20-S/RKLF40H-S RKLF40-S	±2.5 µm/m achievable with two-point error correction ±3 µm/m achievable with two-point error correction
Installation temperature ³		+10 °C to +35 °C
Coefficient of thermal expansion (at 20 °C)		Matches that of substrate material when scale ends fixed by epoxy mounted end clamp
Length ⁴		20 mm to 1 m in 10 mm increments 1 m to 10 m in 1 m increments Overall length = measuring length + 70 mm Scale length = measuring length + 40 mm
Mass		4.6 g/m
End fixing		Epoxy mounted end clamps (A-9523-4015) Approved epoxy adhesive (A-9531-0342) Scale end movement typically < 1 µm ⁵

¹ 20 µm RKLF scale is not suitable for partial arc applications.

² Only the selected reference mark is bi-directionally repeatable.

³ Ensure that the scale and end clamps are installed following the installation process described in the *ATOM DX™ linear encoder systems* installation guide (Renishaw part no. M-9414-9446).

⁴ The maximum recommended axis length is 1 m for 20 µm RKLF systems.

⁵ To limit the maximum tension in the scale $(CTE_{\text{substrate}} - CTE_{\text{scale}}) \times (T_{\text{use extreme}} - T_{\text{install}}) \leq 550 \mu\text{m/m}$ where $CTE_{\text{scale}} = \sim 10.1 \mu\text{m/m}^\circ\text{C}$.

RTLFL tape scale installation drawing

Dimensions and tolerances in mm

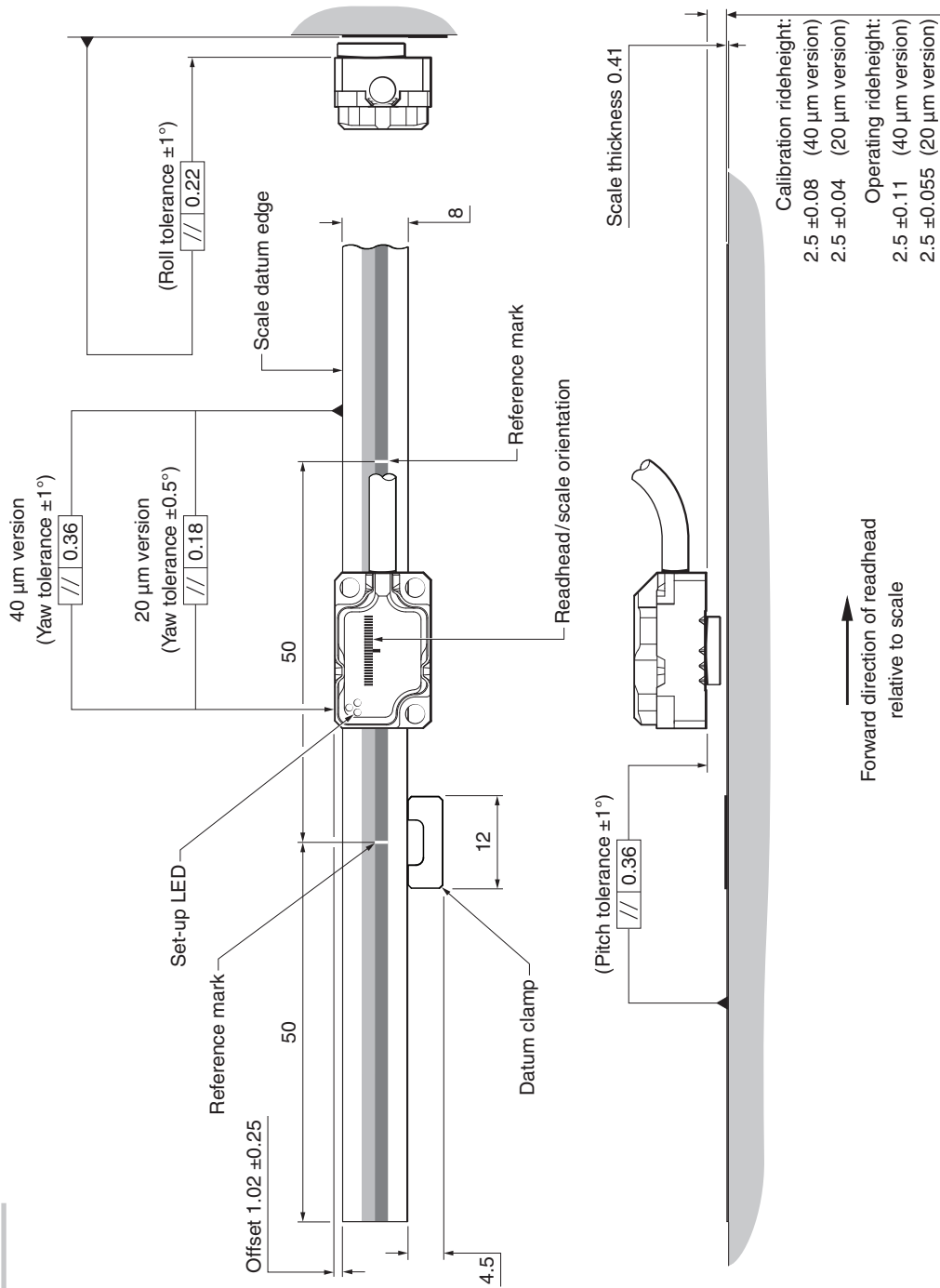

NOTE: ATOM DX cabled readhead variant shown.¹

¹ For readhead dimensions see pages 4 and 5.

RTLIF tape scale technical specifications

Material	Hardened and tempered martensitic stainless steel fitted with a self-adhesive backing tape
Form (height x width)	0.41 mm x 8 mm (including adhesive)
Scale pitch	20 µm and 40 µm
Datum fixing	Adhesive datum clamp A-9585-0028 secured with Loctite® 435
Reference mark	Auto-phase optical reference mark repeatable to unit of resolution throughout specified speed and temperature range Customer deselectable reference marks at 50 mm spacing ¹ Reference mark in the centre of scale for lengths < 100 mm
Accuracy (at 20 °C)	RTLIF20-S/RTLIF40H-S ±5 µm/m RTLIF40-S ±15 µm/m
Coefficient of thermal expansion (at 20 °C) ²	10.1 ±0.2 µm/m/°C
Length ³	20 mm to 1 m in 10 mm increments 1 m to 10 m in 1 m increments Scale length = measuring length + 6 mm (without optional end covers)
Mass	12.2 g/m

¹ Only the selected reference mark is bi-directionally repeatable.

² The substrate coefficient of thermal expansion does not need to match that of the scale.

³ The maximum recommended axis length is 1 m for 20 µm RTLIF systems.

RCLC glass spar installation drawing

Dimensions and tolerances in mm

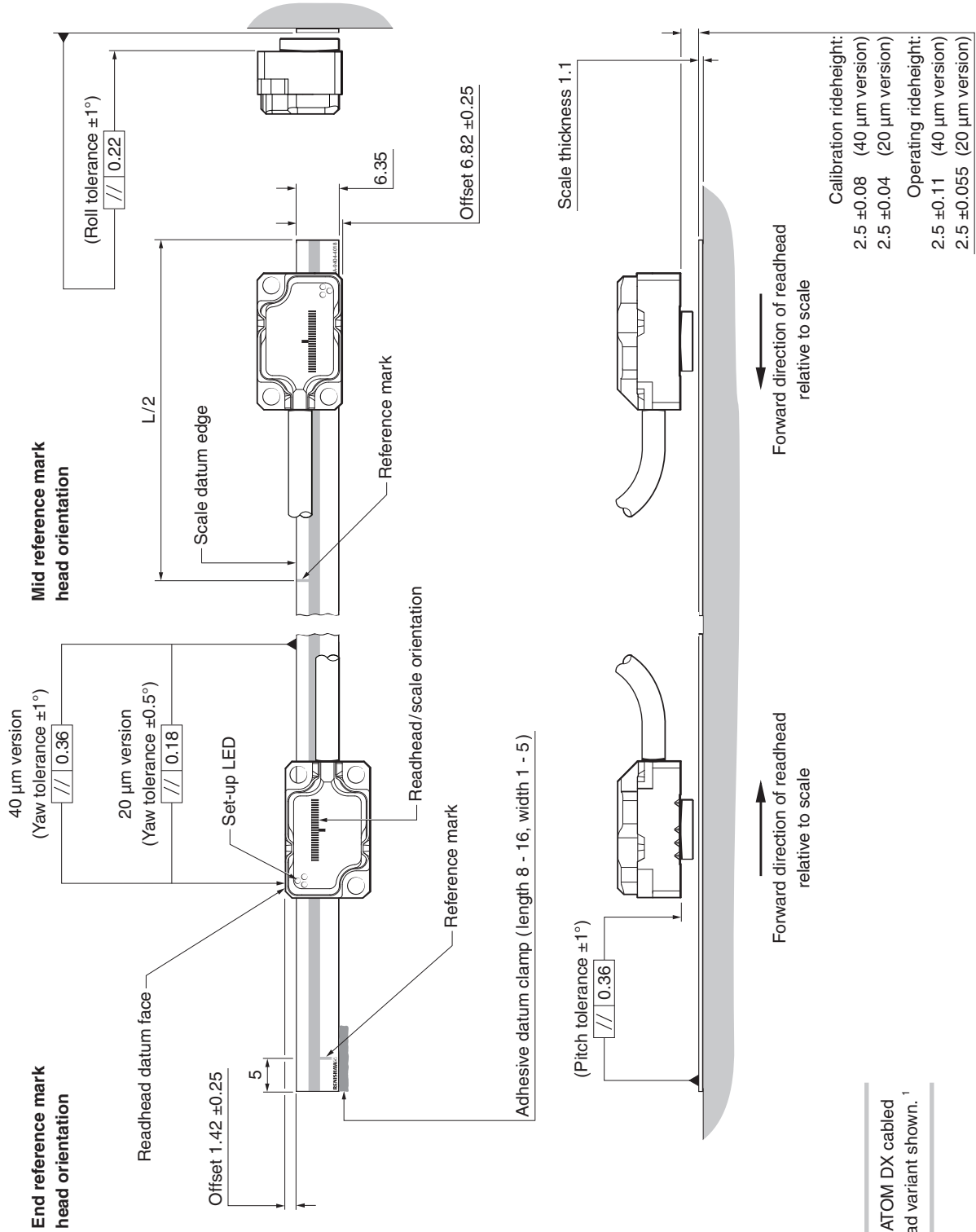

NOTE: ATOM DX cabled readhead variant shown.¹

¹ For readhead dimensions see pages 4 and 5.

RCLC glass spar technical specifications

Material	Soda-lime glass fitted with a self-adhesive backing tape
Form (height x width)	1.1 mm x 6.35 mm (including adhesive)
Pitch	20 µm and 40 µm
Datum fixing	Fillet of adhesive (A-9531-0342) on one side of the scale
Reference mark	Auto-phase optical reference mark repeatable to unit of resolution throughout specified speed and temperature range Either mid or one end of travel; determined by orientation of the readhead
Accuracy (at 20 °C)	±3 µm
Coefficient of thermal expansion	~8 µm/m/°C
Mass	13.9 g/m

RCLC glass spar lengths

Overall length L (mm)	Measuring length ML (mm)
10	7
18	15
30	27
55	52
80	77
100	97
105	102
130	127

CENTRUM CSF40 rotary disc with external reference mark installation drawing

Dimensions and tolerances in mm

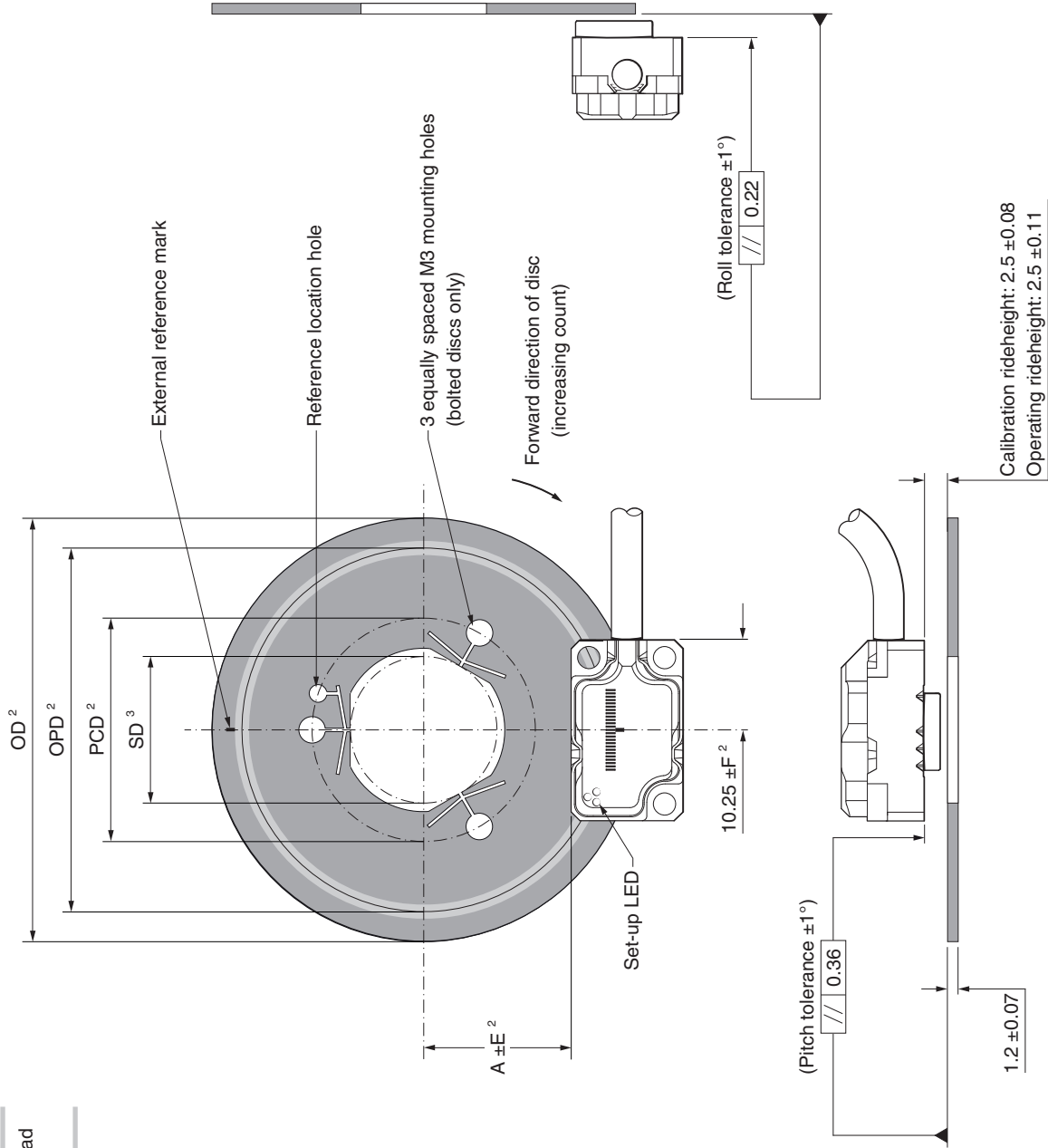

NOTE: ATOM DX cabled readhead on bolted CSF40 shown.¹

¹ For readhead dimensions see pages 4 and 5.

² The tolerances are defined on page 15 and the dimensions on page 16.

³ The inner diameter of the disc is designed to fit a shaft diameter equal to SD with a tolerance of h6. The dimension of SD is defined on page 16.

CENTRUM CSF40 rotary disc with internal reference mark installation drawing

Dimensions and tolerances in mm

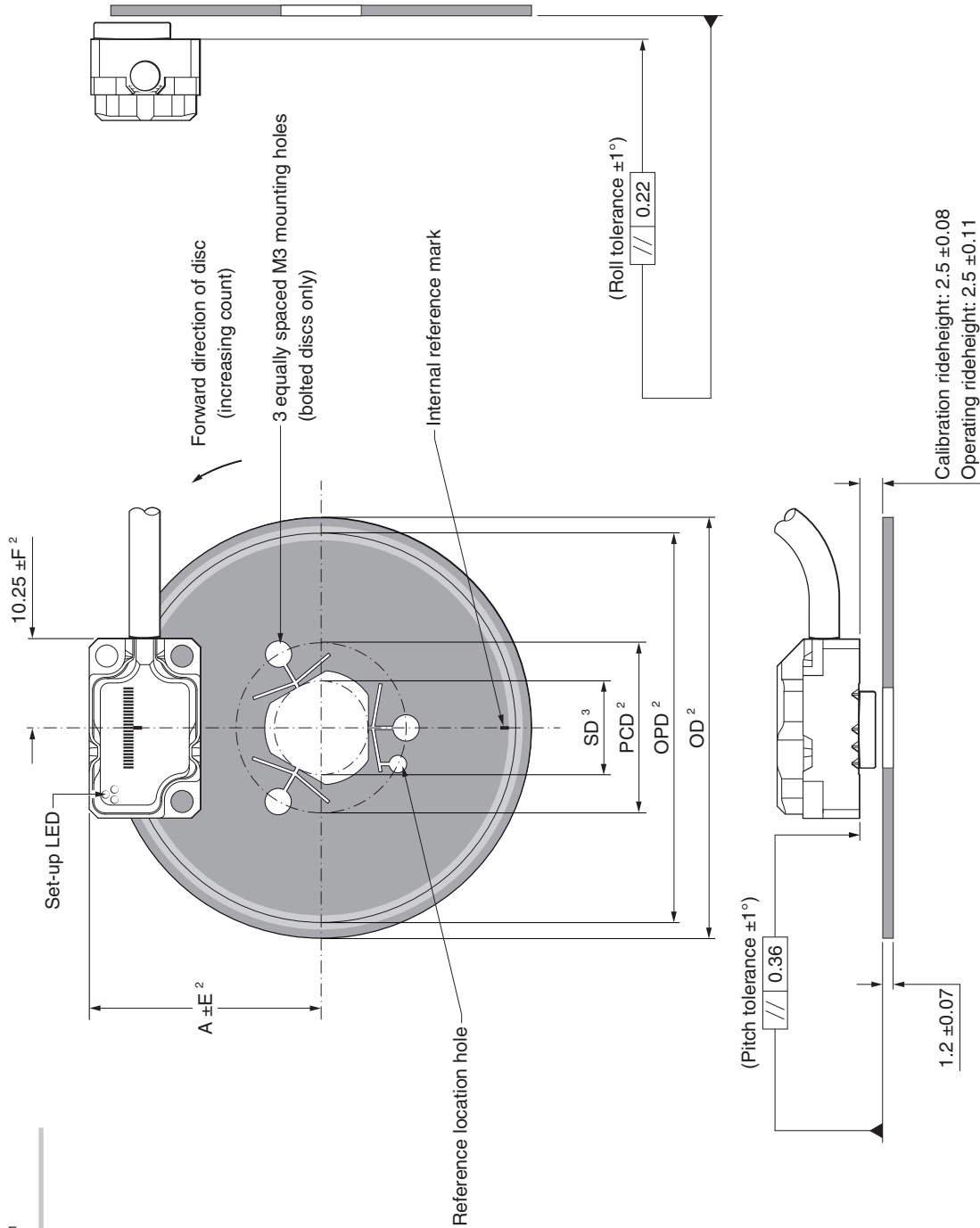

NOTE: ATOM DX cabled readhead on bolted CSF40 shown.¹

¹ For readhead dimensions see pages 4 and 5.

² The tolerances are defined on page 15 and the dimensions on page 16.

³ The inner diameter of the disc is designed to fit a shaft diameter equal to SD with a tolerance of h6. The dimension of SD is defined on page 16.

CENTRUM CSF40 rotary disc tolerances

Radial and longitudinal tolerances

Optical diameter (mm)	Radial tolerance (mm)
OPD	E
< 20	0.100
< 30	0.125
< 40	0.175
≥ 40	0.200

Optical diameter (mm)	Longitudinal tolerance (mm)
OPD	F
< 30	0.100
< 45	0.150
< 60	0.200
≥ 60	0.300

CENTRUM CSF40 rotary disc dimensions

CSF40 discs can be customised to fit most applications. The limits and dependencies specified below can be used to create a dimensionally representative approximation of a custom CSF40 disc.

The absolute limits are the physical limitations that dictate the maximum and minimum possible size for a CSF40 disc. The dependencies limit the parameter values in relation to each other.

NOTE: This information does not provide a total and comprehensive guide on how to design a disc. Contact your local Renishaw representative for additional support.

Absolute limits

Mounting	Reference mark	Line count		OPD ¹ (mm)		SD ¹ (mm)		OD ¹ (mm)	
		Minimum	Maximum	Minimum	Maximum	Minimum	Maximum	Minimum	Maximum
Bolted	External	2 482	8 890	31.6	113.2	7.0	88.6	38.4	120
	Internal	3 204	9 142	40.8	116.4	7.0	82.6	44.4	120
Clamped	External	1 900	8 890	24.2	113.2	7.0	95.0	31.0	120
	Internal	2 624	9 142	33.4	116.4	7.0	90.0	37.0	120

Dependencies

IMPORTANT: The line count (LC) must always be a whole number.

General

- All dimensions in mm.
- The outer diameter (OD) – the shaft diameter (SD) must be ≤ 40 mm.
- The shaft diameter (SD) must be $\leq 19/24 \times OD$.
- The optical diameter (OPD) = $\frac{LC \times 0.04}{\pi}$

Mounting specific

Mounting	Reference mark	SD ¹	OD ¹	PCD ¹	Readhead (A)
Bolted	External	$\leq OPD - 24.6$	$\geq OPD + 6.8$	$\leq OPD - 15.9$ and $\geq SD + 8.7$	$OPD/2 - 4.11$
	Internal	$\leq OPD - 33.8$	$\geq OPD + 3.6$	$\leq OPD - 25.1$ and $\geq SD + 8.7$	$OPD/2 + 4.11$
Clamped	External	$\leq OPD - 17.2$	$\geq OPD + 6.8$	N/A	$OPD/2 - 4.11$
	Internal	$\leq OPD - 26.4$	$\geq OPD + 3.6$	N/A	$OPD/2 + 4.11$

¹ OD = outer diameter; SD = shaft diameter; OPD = optical diameter; PCD = bolt hole diameter.

CENTRUM CSF40 rotary disc technical specifications

Material	304 grade stainless-steel
Form	1.2 mm thick
Pitch	40 μm
Reference mark	Single reference mark, external or internal
Installed accuracy (scale to shaft)	$\leq \pm 10 \mu\text{m}$
Eccentricity (scale to shaft)	Typically $\leq \pm 5 \mu\text{m}$
Graduation accuracy	Typically $\leq \pm 0.5 \mu\text{m}$
Coefficient of thermal expansion (at 20 °C)	$15.5 \pm 0.5 \mu\text{m}/\text{m}/^\circ\text{C}$
Density	$8000 \text{ kg}/\text{m}^3$

RCDM rotary disc installation drawing

Dimensions and tolerances in mm

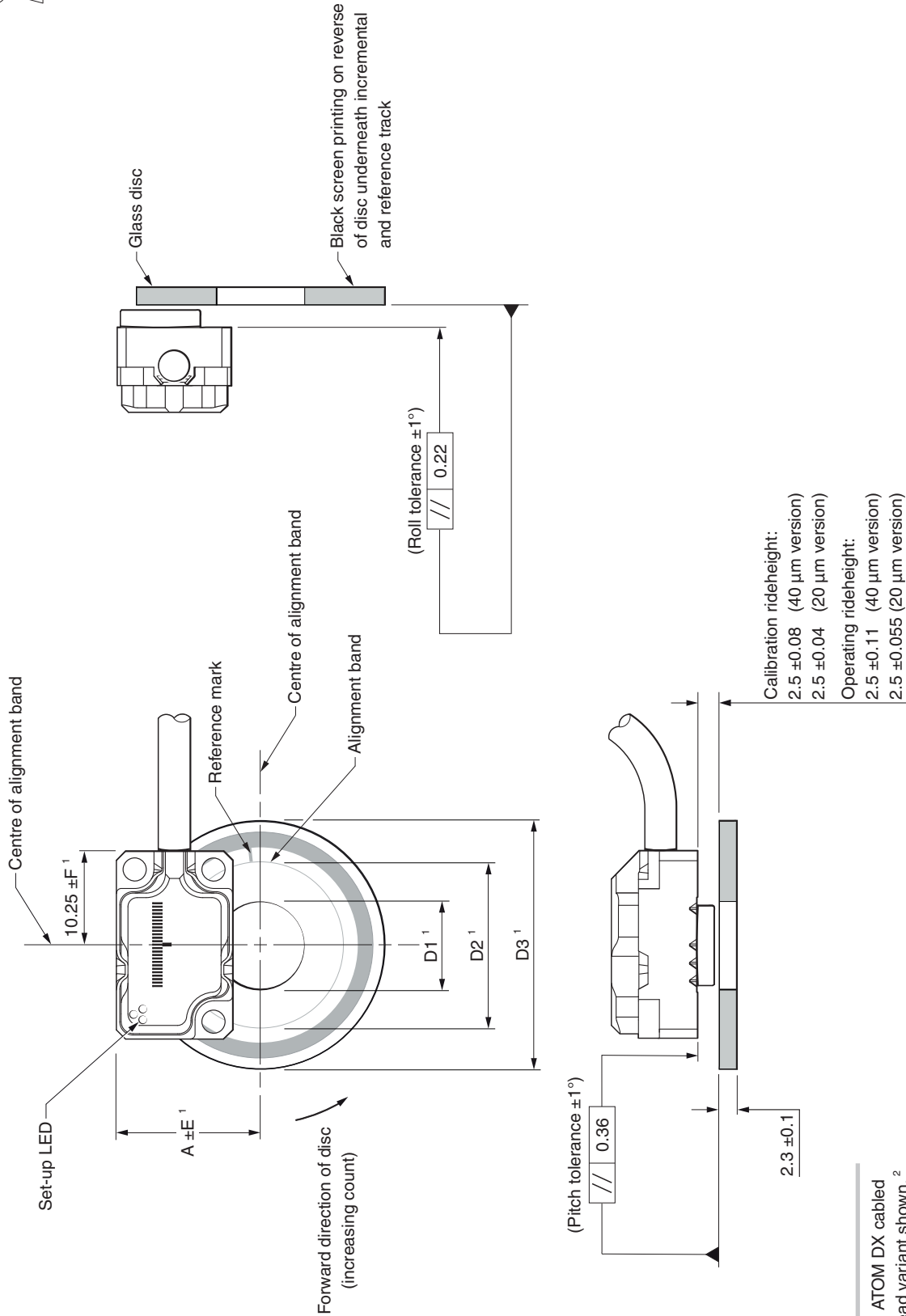

NOTE: ATOM DX cabled readhead variant shown. ²

For detailed information see the *ATOM DX™ rotary encoder systems* installation guide (Renishaw part no. M-9414-9447).

¹ The dimensions and tolerances are defined on page 19.

² For readhead dimensions see pages 4 and 5.

RCDM rotary disc dimensions and tolerances

20 µm discs

Optical diameter (mm)	Line count	Nominal outer diameter (mm) ¹	D1 (mm)	D2 (mm)	D3 (mm)	A (mm)	Radial tolerance E (mm)	Longitudinal tolerance F (mm)
26.08	4 096	30	12.8	21.15	29.9	17.15	0.1	0.075
31.83	5 000	36	12.8	26.9	35.9	20.03	0.125	0.075
45.84	7 200	50	25.5	40.9	49.9	27.03	0.125	0.075
52.15	8 192	56	25.5	47.25	55.9	30.19	0.125	0.1
63.66	10 000	68	25.5	58.55	67.9	35.94	0.15	0.125
104.3	16 384	108	50.9	99.2	107.9	56.26	0.2	0.225

40 µm discs

Optical diameter (mm)	Line count	Nominal outer diameter (mm) ¹	D1 (mm)	D2 (mm)	D3 (mm)	A (mm)	Radial tolerance E (mm)	Longitudinal tolerance F (mm)
13.04	1 024	17	3.275	8.1	16.9	10.63	0.1	0.1
15.92	1 250	20	3.275	11	19.9	12.07	0.1	0.1
21.01	1 650	25	6.46	16.1	24.9	14.62	0.125	0.1
22.92	1 800	27	9.625	18	26.9	15.57	0.125	0.1
26.08	2 048	30	12.8	21.15	29.9	17.15	0.125	0.1
31.83	2 500	36	12.8	26.9	35.9	20.03	0.175	0.15
45.84	3 600	50	25.5	40.9	49.9	27.03	0.2	0.2
52.15	4 096	56	25.5	47.25	55.9	30.19	0.2	0.2
63.66	5 000	68	25.5	58.55	67.9	35.94	0.2	0.3
104.3	8 192	108	50.9	99.2	107.9	56.26	0.2	0.3

¹ Special disc sizes are available on request

RCDM rotary disc technical specifications

Material	Soda-lime glass
Form	2.3 mm thick
Pitch	20 µm and 40 µm
Reference mark	Single reference mark
Coefficient of thermal expansion	~8 µm/m/°C

RCDM rotary disc graduation accuracy

Optical diameter (mm)	Nominal outer diameter (mm)	Graduation accuracy (arc seconds)
13.04	17	15.81
15.92	20	12.95
21.01	25	9.82
22.92	27	9
26.08	30	7.91
31.83	36	6.49
45.84	50	4.5
52.15	56	3.95
63.66	68	3.24
104.3	108	2.78

Speed

20 µm encoder

Clocked output option (MHz)	Maximum speed (m/s)						Minimum edge separation ¹ (ns)
	Readhead type						
	D (5 µm)	X (1 µm)	Z (0.5 µm)	W (0.2 µm)	Y (0.1 µm)	H (50 nm)	
50	10	10	10	7.25	3.63	1.813	25.1
40	10	10	10	5.80	2.90	1.450	31.6
25	10	10	9.06	3.63	1.81	0.906	51.0
20	10	10	8.06	3.22	1.61	0.806	57.5
12	10	10	5.18	2.07	1.04	0.518	90.0
10	10	8.53	4.27	1.71	0.85	0.427	109
08	10	6.91	3.45	1.38	0.69	0.345	135
06	10	5.37	2.69	1.07	0.54	0.269	174
04	10	3.63	1.81	0.73	0.36	0.181	259
01	4.53	0.91	0.45	0.18	0.09	0.045	1038

Clocked output option (MHz)	Maximum speed (m/s)					Minimum edge separation ¹ (ns)
	Readhead type					
	M (40 nm)	I (20 nm)	O (10 nm)	Q (5 nm)	R (2.5 nm)	
50	1.450	0.725	0.363	0.181	0.091	25.1
40	1.160	0.580	0.290	0.145	0.073	31.6
25	0.725	0.363	0.181	0.091	0.045	51.0
20	0.645	0.322	0.161	0.081	0.040	57.5
12	0.414	0.207	0.104	0.052	0.026	90.0
10	0.341	0.171	0.085	0.043	0.021	109
08	0.276	0.138	0.069	0.035	0.017	135
06	0.215	0.107	0.054	0.027	0.013	174
04	0.145	0.073	0.036	0.018	0.009	259
01	0.036	0.018	0.009	0.005	0.002	1038

Angular speed depends on disc optical diameter. Use the following equation to convert to rev/min.

$$\text{Angular speed (rev/min)} = \frac{V \times 1000 \times 60}{\pi D} \quad \text{Where } V = \text{maximum linear speed (m/s) and } D = \text{optical diameter of chosen disc in mm}$$

¹ For a readhead with a 1 m cable

40 µm encoder

Clocked output option (MHz)	Maximum speed (m/s)						Minimum edge separation ¹ (ns)
	Readhead type						
	T (10 µm)	D (5 µm)	G (2 µm)	X (1 µm)	Z (0.5 µm)	W (0.2 µm)	
50	20	20	20	20	18.13	7.25	25.1
40	20	20	20	20	14.50	5.80	31.6
25	20	20	20	18.13	9.06	3.63	51.0
20	20	20	20	16.11	8.06	3.22	57.5
12	20	20	20	10.36	5.18	2.07	90.0
10	20	20	17.06	8.53	4.27	1.71	109
08	20	20	13.81	6.91	3.45	1.38	135
06	20	20	10.74	5.37	2.69	1.07	174
04	20	18.13	7.25	3.63	1.81	0.73	259
01	9.06	4.53	1.81	0.91	0.45	0.18	1038



Clocked output option (MHz)	Maximum speed (m/s)						Minimum edge separation ¹ (ns)
	Readhead type						
	Y (0.1 µm)	H (50 nm)	M (40 nm)	I (20 nm)	O (10 nm)	Q (5 nm)	
50	3.63	1.813	1.450	0.725	0.363	0.181	25.1
40	2.90	1.450	1.160	0.580	0.290	0.145	31.6
25	1.81	0.906	0.725	0.363	0.181	0.091	51.0
20	1.61	0.806	0.645	0.322	0.161	0.081	57.5
12	1.04	0.518	0.414	0.207	0.104	0.052	90.0
10	0.85	0.427	0.341	0.171	0.085	0.043	109
08	0.69	0.345	0.276	0.138	0.069	0.035	135
06	0.54	0.269	0.215	0.107	0.054	0.027	174
04	0.36	0.181	0.145	0.073	0.036	0.018	259
01	0.09	0.045	0.036	0.018	0.009	0.005	1038

Angular speed depends on disc optical diameter. Use the following equation to convert to rev/min.

$$\text{Angular speed (rev/min)} = \frac{V \times 1000 \times 60}{\pi D} \quad \text{Where } V = \text{maximum linear speed (m/s) and } D = \text{optical diameter of chosen disc in mm}$$

¹ For a readhead with a 1 m cable

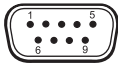
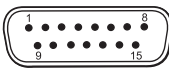
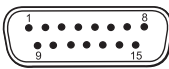
Output signals

			Cabled				Top Exit	
								
Function	Signal	Colour	9-way D-type (A)	15-way D-type (D)	15-way D-type alternative pin-out (H)	10-way JST ¹ (K)	10-way JST ² (Z)	
Power	5 V	Brown	5	7, 8	4, 12	10	10	
	0 V	White	1	2, 9	2, 10	2	9	
Incremental	A	+	2	14	1	9	5	
		-	6	6	9	7	6	
	B	+	4	13	3	4	8	
		-	Green	8	5	11	1	7
Reference mark	Z	+	3	12	14	8	4	
		-	Grey	7	4	7	5	3
Alarm	E	-	Orange	-	3	13	6	2
Remote CAL ³	CAL	Clear	9	1	5	3	1	
Shield	-	Screen	Case	Case	Case	Ferrule	-	

NOTE: Top exit cables are terminated with the 'K' pin-out or the 'D' pin-out dependent upon which top-exit readhead cable is used. See available top exit readhead cables on page 31.

¹ PCB mount mating connectors: Top entry (BM10B-SRSS-TB); Side entry (SM10B-SRSS-TB).

² Connector on top exit readhead only: Mating connector (10SUR - 32S).

³ Remote CAL line must be connected for use with the ADTi-100.

Electrical connections

Grounding and shielding

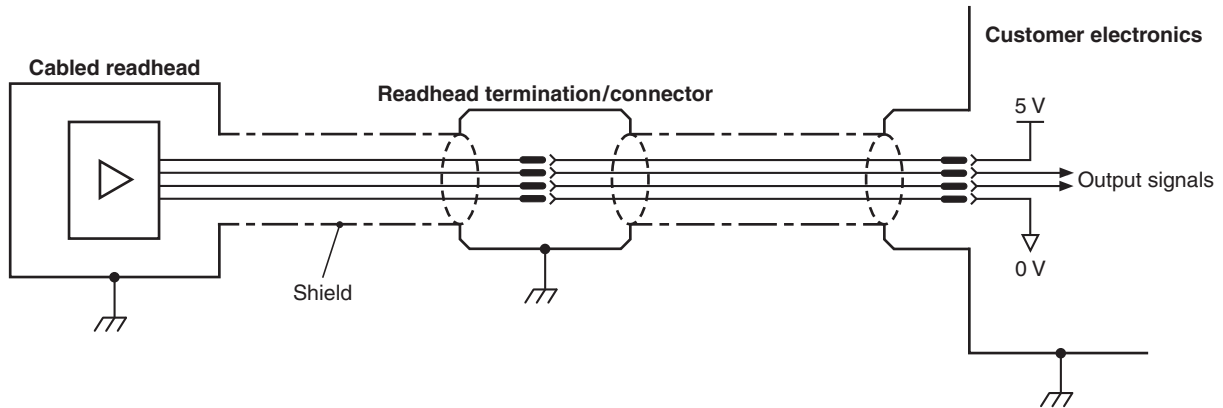

IMPORTANT: The shield should be connected to the machine earth (Field Ground). For JST variants the ferrule should be connected to the machine earth.

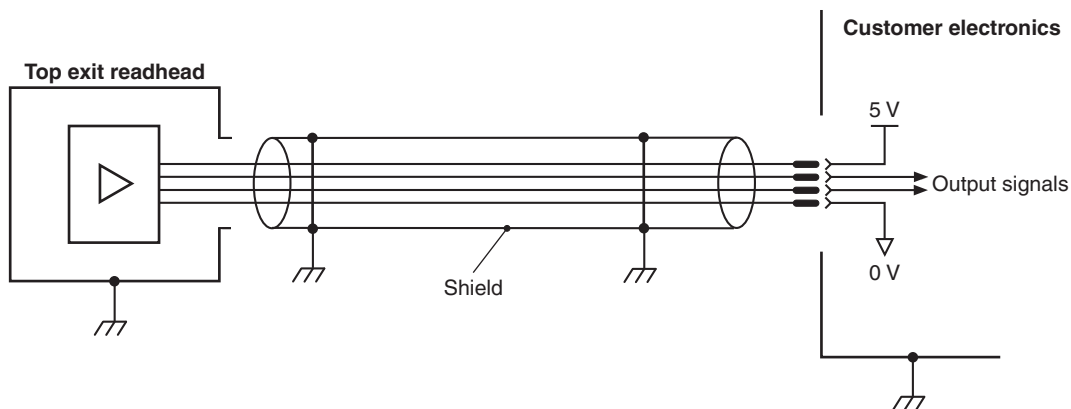

For more information on top exit readheads refer to the relevant ATOM DX installation guide.

Maximum readhead cable length: 3 m

Maximum extension cable length: Dependent on cable type, readhead cable length and clock speed.
Contact your local Renishaw representative for more information.

NOTE: The maximum cable length between the readhead and the ADTi-100 is 3 m.

Recommended signal termination

Digital outputs

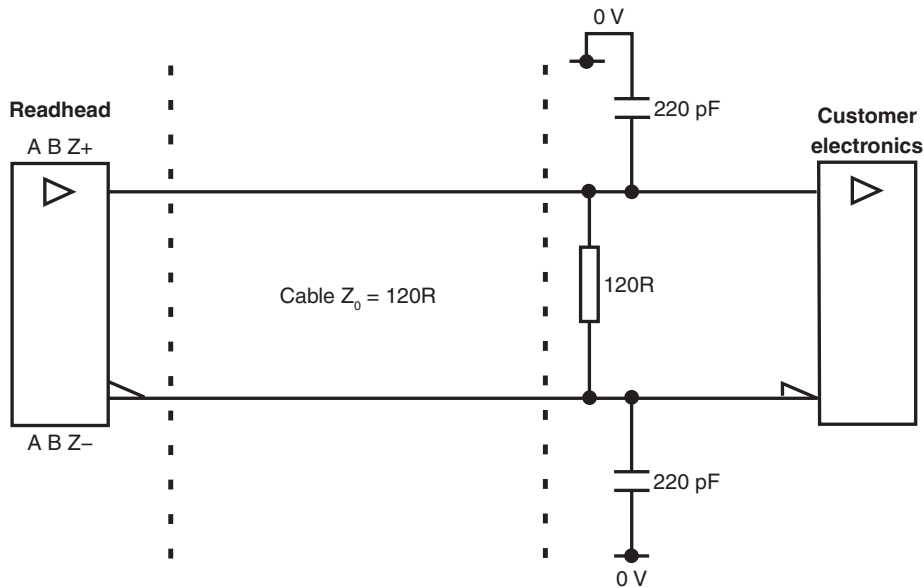

Standard RS422A line receiver circuitry.

The capacitors are recommended for improved noise immunity.

Single ended alarm signal termination

(Not available with 'A' cable termination)

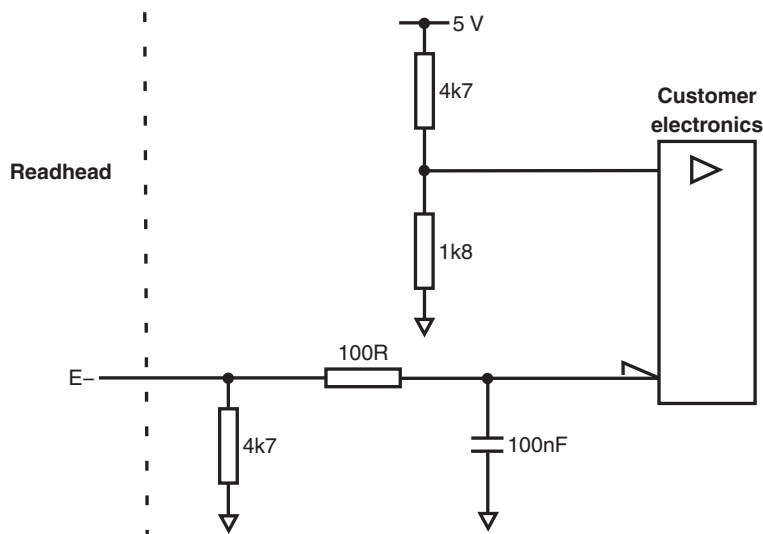

Remote CAL operation

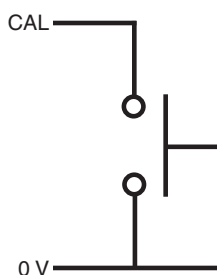

Remote system calibration (CAL) is possible via the CAL pin.

Output specifications

Digital output signals

Form – Square wave differential line driver to EIA RS422A

Incremental¹

2 channels A and B in quadrature (90° phase shifted)

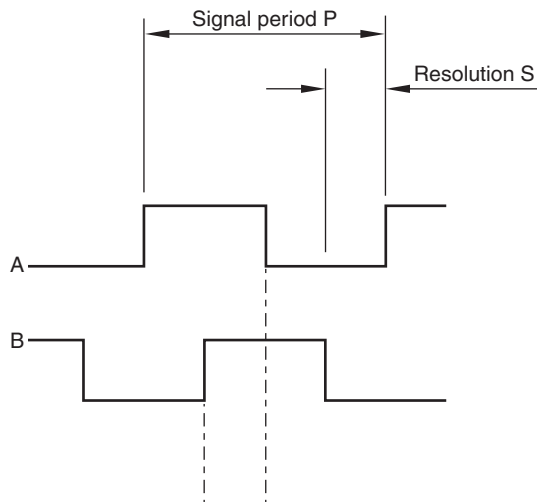

Resolution option code	P (μm)	S (μm)
T ²	40	10
D	20	5
G ²	8	2
X	4	1
Z	2	0.5
W	0.8	0.2
Y	0.4	0.1
H	0.2	0.05
M	0.16	0.04
I	0.08	0.02
O	0.04	0.01
Q	0.02	0.005
R ³	0.01	0.0025

Reference¹

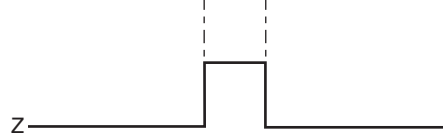

Synchronised pulse Z, duration as resolution.

Bi-directionally repeatable.⁴

Alarm

Line driven (Asynchronous pulse)

(Not available with 'A' cable termination)

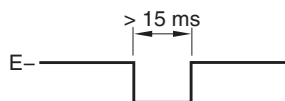

Alarm asserted when:

- Signal amplitude < 20% or > 135%
- Readhead speed too high for reliable operation

or 3-state alarm

Differentially transmitted signals forced open circuit for > 15 ms when alarm conditions valid.

¹ For clarity, the inverse signals are not shown.

² 40 μm ATOM DX only

³ 20 μm ATOM DX only

⁴ Only the calibrated reference mark is bi-directionally repeatable.

ATOM DX 20 µm part numbers

A2 A 0 X 10 D 50 B

Series

A2 - 20 µm ATOM DX

Variant

A - Cabled

L - Top exit ('00' cable length and 'Z' cable termination only)

Scale type compatibility

Linear	Rotary
	RCDM20 glass disc
	Optical diameter
0 - RTLF20	1 - ≥ 77 mm
0 - RKLF20 ¹	2 - ≥ 42.4 mm to < 77 mm
1 - RCLC20 glass spar	3 - ≥ 31.4 mm to < 42.4 mm
-	4 - ≥ 26.1 mm to < 31.4 mm

Resolution

D - 5 µm	Y - 0.1 µm	O - 10 nm
X - 1 µm	H - 50 nm	Q - 5 nm
Z - 0.5 µm	M - 40 nm	R - 2.5 nm
W - 0.2 µm	I - 20 nm	

Cable length

00 - no cable ('L' variant and 'Z' cable termination only)	15 - 1.5 m
02 - 0.2 m	20 - 2.0 m
05 - 0.5 m	30 - 3.0 m
10 - 1.0 m	

Cable termination

A - 9-way D-type	K - 10-way JST
D - 15-way D-type (standard pin-out)	Z - 10-way JST readhead connector ('L' variant and '00' cable length only)
H - 15-way D-type (alternative pin-out)	

Clocked output option²

50 - 50 MHz	12 - 12 MHz	04 - 4 MHz
40 - 40 MHz	10 - 10 MHz	01 - 1 MHz
25 - 25 MHz	08 - 8 MHz	
20 - 20 MHz	06 - 6 MHz	

Alarm format

B - Line driven alarm³
F - 3-state alarm

NOTE: Not all the combinations are valid. Check valid configurations online at www.renishaw.com/epc.

¹ RKLF20 is not suitable for partial arc applications.

² Additional clocked output options available. Contact your local Renishaw representative for further details.

³ No alarm output on readheads with 'A' cable termination

ATOM DX 40 µm part numbers

A4 A 0 X 10 D 50 B

Series

A4 - 40 µm ATOM DX

Variant

A - Cabled

L - Top exit ('00' cable length and 'Z' cable termination only)

Scale type compatibility

Linear	Rotary	
	RCDM40 glass disc	CENTRUM CSF40 metal disc
	Optical diameter	Optical diameter
0 - RTLF40	1 - ≥ 30.6 mm	C - ≥ 47.0 mm
0 - RKLF40	2 - ≥ 19.7 mm to < 30.6 mm	D - ≥ 23.0 mm to < 47.0 mm
1 - RCLC40 glass spar	3 - ≥ 15.2 mm to < 19.7 mm	E - ≥ 16.0 mm to < 23.0 mm
-	4 - ≥ 13.0 mm to < 15.2 mm	-

Resolution

T - 10 µm	Z - 0.5 µm	M - 40 nm
D - 5 µm	W - 0.2 µm	I - 20 nm
G - 2 µm	Y - 0.1 µm	O - 10 nm
X - 1 µm	H - 50 nm	Q - 5 nm

Cable length

00 - no cable ('L' variant and 'Z' cable termination only)	15 - 1.5 m
02 - 0.2 m	20 - 2.0 m
05 - 0.5 m	30 - 3.0 m
10 - 1.0 m	

Cable termination

A - 9-way D-type	K - 10-way JST
D - 15-way D-type (standard pin-out)	Z - 10-way JST readhead connector ('L' variant and '00' cable length only)
H - 15-way D-type (alternative pin-out)	

Clocked output option ¹

50 - 50 MHz	12 - 12 MHz	04 - 4 MHz
40 - 40 MHz	10 - 10 MHz	01 - 1 MHz
25 - 25 MHz	08 - 8 MHz	
20 - 20 MHz	06 - 6 MHz	

Alarm format

B - Line driven alarm ²
F - 3-state alarm

NOTE: Not all the combinations are valid. Check valid configurations online at www.renishaw.com/epc.

¹ Additional clocked output options available. Contact your local Renishaw representative for further details.

² No alarm output on readheads with 'A' cable termination

Linear scale part numbers

RTLTF tape scale

Scale type	Scale pitch	Length	Increments	Part number (where xxxx is the length in cm) ¹	ATOM DX readhead scale type compatibility
RTLTF20-S	20 µm	20 mm to 1 m	10 mm	A-9406-xxxx	0
		1 m to 10 m ²	1 m		
RTLTF40H-S	40 µm (high accuracy)	20 mm to 1 m	10 mm	A-9408-xxxx	0
		1 m to 10 m ²	1 m		
RTLTF40-S	40 µm	20 mm to 1 m	10 mm	A-9407-xxxx	0
		1 m to 10 m ²	1 m		

RKLF mastered tape scale

Scale type	Scale pitch	Length	Increments	Part number (where xxxx is the length in cm) ³	ATOM DX readhead scale type compatibility
RKLF20-S	20 µm ⁴	20 mm to 1 m	10 mm	A-6767-xxxx	0
		1 m to 10 m	1 m		
RKLF40H-S	40 µm (high accuracy) ⁴	20 mm to 1 m	10 mm	A-6771-xxxx	0
		1 m to 10 m	1 m		
RKLF40	40 µm	20 mm to 1 m	10 mm	A-6769-xxxx	0
		1 m to 10 m	1 m		

RCLC glass spar

Length (mm)	20 µm	40 µm	ATOM DX readhead scale type compatibility
10	A-9404-2010	A-9404-4010	1
18	A-9404-2018	A-9404-4018	1
30	A-9404-2030	A-9404-4030	1
55	A-9404-2055	A-9404-4055	1
80	A-9404-2080	A-9404-4080	1
100	A-9404-2100	A-9404-4100	1
105	A-9404-2105	A-9404-4105	1
130	A-9404-2130	A-9404-4130	1

¹ Ordering A-9408-0070 for example will result in a 70 cm length of RTLTF40H-S scale.

² Lengths greater than 10 m are available on request.

³ Ordering A-6767-0070 for example will result in a 70 cm length of RKLF20-S scale.

⁴ Not recommended for partial arc applications.

Rotary disc part numbers

RCDM rotary discs (20 µm version)

Optical diameter (mm)	Nominal outer diameter (mm)	Part number	ATOM DX readhead scale type compatibility
26.08	30	A-9405-2030	4
31.83	36	A-9405-2036	3
45.84	50	A-9405-2050	2
52.15	56	A-9405-2056	2
63.66	68	A-9405-2068	2
104.3	108	A-9405-2108	1

RCDM rotary discs (40 µm version)

Optical diameter (mm)	Nominal outer diameter (mm)	Part number	ATOM DX readhead scale type compatibility
13.04	17	A-9405-4017	4
15.92	20	A-9405-4020	3
21.01	25	A-9405-4025	2
22.92	27	A-9405-4027	2
26.08	30	A-9405-4030	2
31.83	36	A-9405-4036	1
45.84	50	A-9405-4050	1
52.15	56	A-9405-4056	1
63.66	68	A-9405-4068	1
104.3	108	A-9405-4108	1

CENTRUM CSF40 rotary discs

CENTRUM CSF40 discs can be customised to fit most applications.

The following part numbers are the existing CENTRUM discs available from Renishaw.

All dimensions and tolerances are in mm.

	Part numbers		
	A-9400-1035	A-9400-1030	A-9400-1025
Mounting method	Bolted	Bolted	Bolted
Reference mark	External	External	External
Line count	3 860	6 360	8 880
Optical diameter (OPD)	49.15	80.98	113.06
Shaft diameter (SD)	24.5	56.5	88.5
Outer diameter (OD)	56	88	120
Bolt holes diameter (PCD)	34.5	66.0	98.5
Readhead installation (A)	20.46 ±0.2	36.83 ±0.2	52.42 ±0.2

NOTE: Other disc diameters are available; contact your local Renishaw representative for more information.

Top exit readhead cable part numbers

Cable length (m)	Cable termination	Part number
0.5	15-way D-type connector ¹	A-9414-1223
1.0		A-9414-1225
1.5		A-9414-1226
3.0		A-9414-1228
0.5	10-way JST connector ²	A-9414-1233
1.0		A-9414-1235
1.5		A-9414-1236
3.0		A-9414-1238

¹ Provided with 'D' pin-out

² Provided with 'K' pin-out

ATOM DX compatible products:

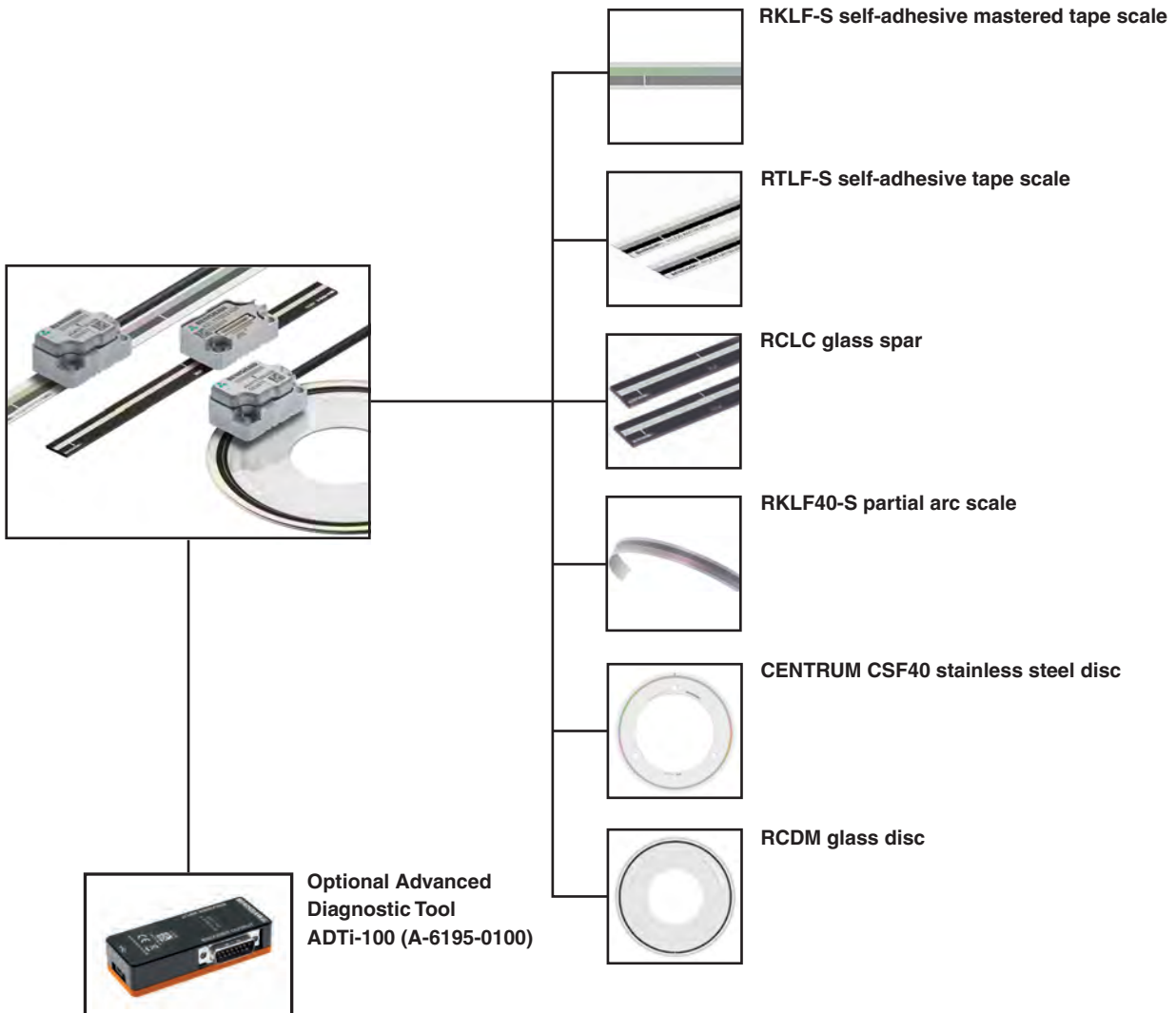

www.renishaw.com/contact



#renishaw

+44 (0) 1453 524524

 uk@renishaw.com

© 2017–2023 Renishaw plc. All rights reserved. This document may not be copied or reproduced in whole or in part, or transferred to any other media or language by any means, without the prior written permission of Renishaw.

RENISHAW® and the probe symbol are registered trade marks of Renishaw plc. Renishaw product names, designations and the mark 'apply innovation' are trade marks of Renishaw plc or its subsidiaries. Other brand, product or company names are trade marks of their respective owners.

WHILE CONSIDERABLE EFFORT WAS MADE TO VERIFY THE ACCURACY OF THIS DOCUMENT AT PUBLICATION, ALL WARRANTIES, CONDITIONS, REPRESENTATIONS AND LIABILITY, HOWSOEVER ARISING, ARE EXCLUDED TO THE EXTENT PERMITTED BY LAW. RENISHAW RESERVES THE RIGHT TO MAKE CHANGES TO THIS DOCUMENT AND TO THE EQUIPMENT, AND/OR SOFTWARE AND THE SPECIFICATION DESCRIBED HEREIN WITHOUT OBLIGATION TO PROVIDE NOTICE OF SUCH CHANGES.

Renishaw plc. Registered in England and Wales. Company no: 1106260. Registered office: New Mills, Wotton-under-Edge, Glos, GL12 8JR, UK.

Part no.: L-9517-9736-04-D

Issued: 07.2023

RKL scale for partial arc applications



Measuring a partial arc of rotation is made easy with Renishaw's flexible RKL encoder scales. The flexible nature of the small cross-sectional area of these scales allows them to be wrapped around a drum, shaft or arc with a minimum radius of 26 mm.

RKL scale is compatible with Renishaw's QUANTIC™, VIONIC™, TONIC™, ATOM DX™, ATOM™ and RESOLUTE™ readheads providing a partial arc solution for a wide range of applications.

RKL scale is installed onto the axis substrate by a self-adhesive backing tape making this a quick, straightforward and inexpensive process. The scale ends are rigidly fixed to the axis substrate by means of epoxy or epoxy fastened end clamps, eliminating the need to drill holes.

- Small cross-sectional area making it ideal for partial arc rotation applications
- Suitable for external radii down to 26 mm
- Compatible with a wide range of Renishaw's incremental and absolute readheads
- 20 µm, 30 µm and 40 µm pitch versions available
- 'Cut-to-length' convenience
- *IN-TRAC*™ optical reference marks
- High solvent immunity

RKL partial arc scale specifications

	Incremental			Absolute
	RKLC20-S	RKLC40-S	RKLF40-S	RKLA30-S
Compatible readheads	VIONiC and TONiC	QUANTiC	ATOM and ATOM DX ¹	RESOLUTE
Form (height x width)	0.15 mm x 6 mm (including adhesive)			
Pitch	20 µm	40 µm	40 µm	30 µm
Accuracy (at 20 °C) (based on neutral axis)	±5 µm/m	±15 µm/m	±15 µm/m	±5 µm/m (including slope and linearity)
Linearity (at 20 °C) (based on neutral axis)	±2.5 µm/m	±3 µm/m	±3 µm/m	-
Supplied length	20 mm to 20 m (> 20 m available on request)		20 mm to 10 m (> 10 m available on request)	20 mm to 21 m
Material	Hardened and tempered stainless steel			
Mass	4.6 g/m			
Coefficient of thermal expansion (at 20 °C)	10.1 ±0.2 µm/m/°C			
Temperature	Storage	-20 °C to +80 °C		
	Operating ²	0 °C to +70 °C		
	Installation	+10 °C to +35 °C		
Humidity	95% relative humidity (non-condensing) to IEC 60068-2-78			
Shock	Operating	500 m/s ² , 11 ms, ½ sine, 3 axes		
Vibration	Operating	300 m/s ² maximum @ 55 to 2000 Hz, 3 axes		
Recommended end fixing	R ≥ 75 mm	Epoxy mounted end clamps (A-9523-4015)		
	R ≥ 26 mm	Approved epoxy adhesive (A-9531-0342)		
Minimum arc radius ³	30 mm	26 mm	26 mm	50 mm

Reference mark ⁴

RKLC20-S and RKLC40-S ⁵	<i>IN-TRAC</i> reference mark, directly embedded into incremental track. Bi-directional position repeatable to unit of resolution throughout specified speed. 50 mm spacing, first reference mark 50 mm from scale end. Reference mark at mid-point of scale length for lengths < 100 mm.
RKLF40-S	Customer de-selectable auto-phase optical reference mark. Bi-directional position repeatable to unit of resolution throughout specified speed. 50 mm spacing, first reference mark 50 mm from scale end. Reference mark at mid-point of scale length for lengths < 100 mm.
RKLA30-S	No reference mark

¹ 40 µm ATOM and ATOM DX readhead variants only.



² To limit the maximum tension in the scale $(CTE_{\text{substrate}} - CTE_{\text{scale}}) \times (T_{\text{use extreme}} - T_{\text{install}}) \leq 550 \mu\text{m/m}$ where $CTE_{\text{scale}} = \sim 10.1 \mu\text{m/m/}^\circ\text{C}$.



³ For smaller radii contact your local Renishaw representative.

⁴ Only the calibrated reference mark is phased.

⁵ Where a specific reference mark location is required, contact your local Renishaw representative for advice on the best method to achieve this.

Compatible readheads

	Incremental		
	VIONIC	TONiC	QUANTiC
			
Readhead size (length x width x height in mm)	35 x 13.5 x 10	35 x 13.5 x 10	35 x 13.5 x 10
Interface	-	Ti, TD or DOP	-
Scale type	RKLC20-S	RKLC20-S	RKLC40-S
Output	Digital resolutions from 5 µm to 2.5 nm direct from the readhead	Analogue 1 Vpp. Digital resolutions from 5 µm to 1 nm from an interface.	Analogue 1 Vpp. Digital resolutions from 10 µm to 50 nm direct from the readhead.
Sub-divisional error (typical)	< ±15 nm	< ±30 nm	< ±150 nm (partial arc radius > 67.5 mm) < ±80 nm ¹ (partial arc radius ≤ 67.5 mm)
Maximum speed	12 m/s	10 m/s	24 m/s ¹
Diagnostic tool	ADTi-100 and ADT View	TONiC diagnostic tool	ADTi-100 and ADT View

	Incremental		
	ATOM ²	ATOM DX ²	RESOLUTE
			
Readhead size (length x width x height in mm)	20.5 x 12.7 x 7.85 (FPC variant: 20.5 x 12.7 x 6.8)	20.5 x 12.7 x 10.85 (Top exit variant: 20.5 x 12.7 x 7.85)	36 x 16.5 x 17.2
Interface	Ri, Ti, ACi	-	DRIVE-CLiQ only
Scale type	RKLF40-S	RKLF40-S	RKLA30-S
Output	Analogue 1 Vpp. Digital resolutions from 10 µm to 2 nm from an interface.	Digital resolutions from 10 µm to 5 nm direct from the readhead.	BiSS, Siemens DRIVECLiQ, FANUC, Mitsubishi, Panasonic, Yaskawa
Sub-divisional error (typical)	< ±120 nm	< ±120 nm	±40 nm
Maximum speed	20 m/s	20 m/s	100 m/s
Diagnostic tool	ATOM diagnostic tool	ADTi-100 and ADT View	ADTa-100 and ADT View

NOTE: If installing RKL scale on a partial arc for a UHV or ETR application, contact your local Renishaw representative for more information.

¹ Digital variants only.

² 40 µm ATOM and ATOM DX readhead variants only.

RKLC partial arc installation drawing

Dimensions and tolerances in mm

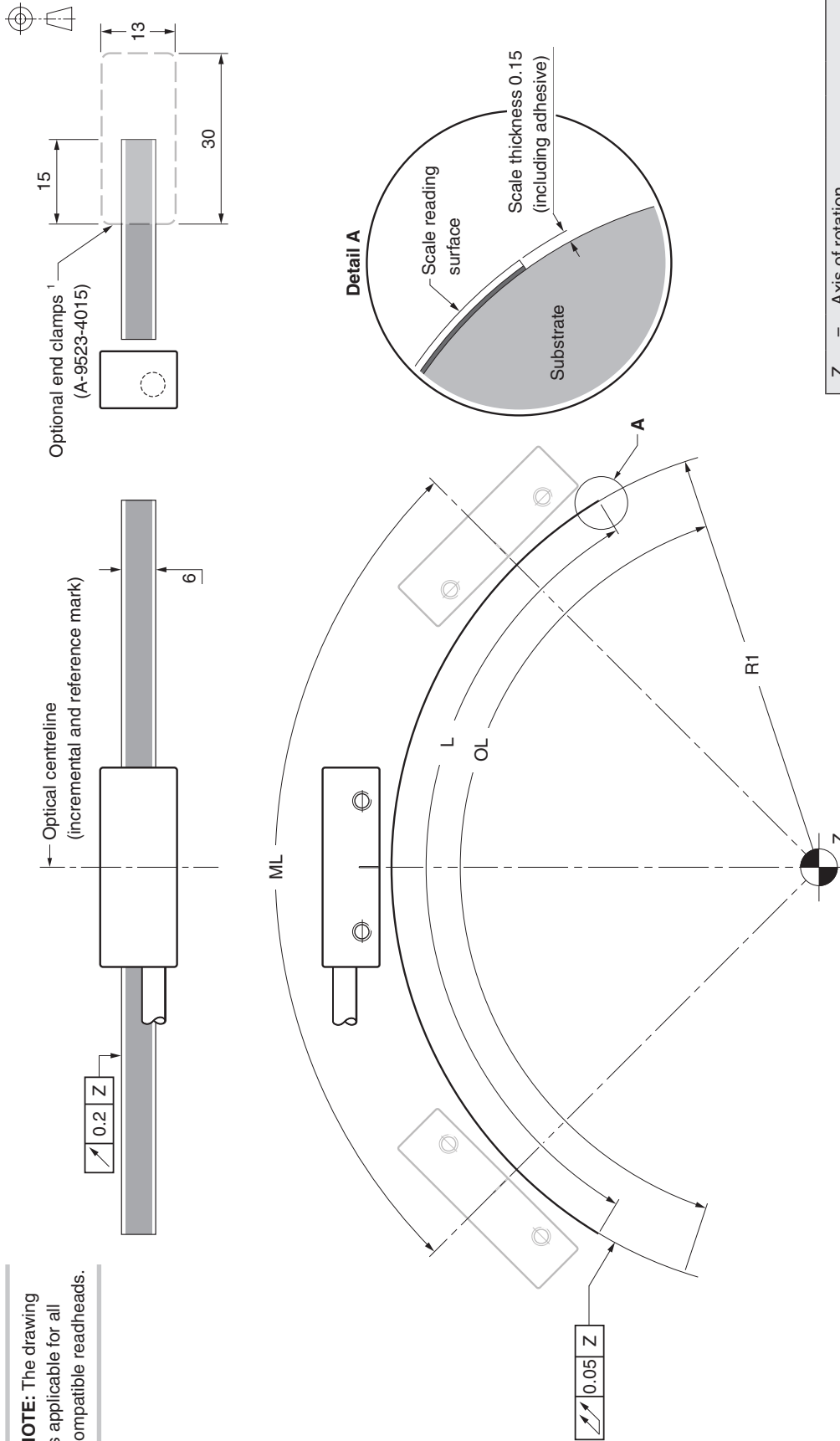

Z	=	Axis of rotation
R1	=	Substrate radius
R ^N	=	Neutral axis radius (R1 + 100 μm)
ML	=	Measuring length
L	=	Scale length ²
		with end clamps
		without end clamps
OL	=	Overall length
		with end clamps
		without end clamps

NOTE: The drawing is applicable for all compatible readheads.

NOTE: The surface roughness of the substrate must be better than 3.2 μm. The parallelism of the scale surface to the axis guideway (readhead ride height variation) must be within 0.05 mm.

¹ When not using end clamps, the scale ends must be secured using an alternative method. For further information refer to *RKLC partial arc installation notes* (Renishaw part no. M-6547-9168) which can be downloaded from www.renishaw.com/encoderinstallationguides.

² When calculating scale length, the first reference mark is 50 mm from scale end.

³ For RESOLUTE systems: To ensure readhead does not clash with the end clamps. L = ML + 66 and OL = ML + 96.

QUANTiC readhead installation drawing ¹

Dimensions and tolerances in mm

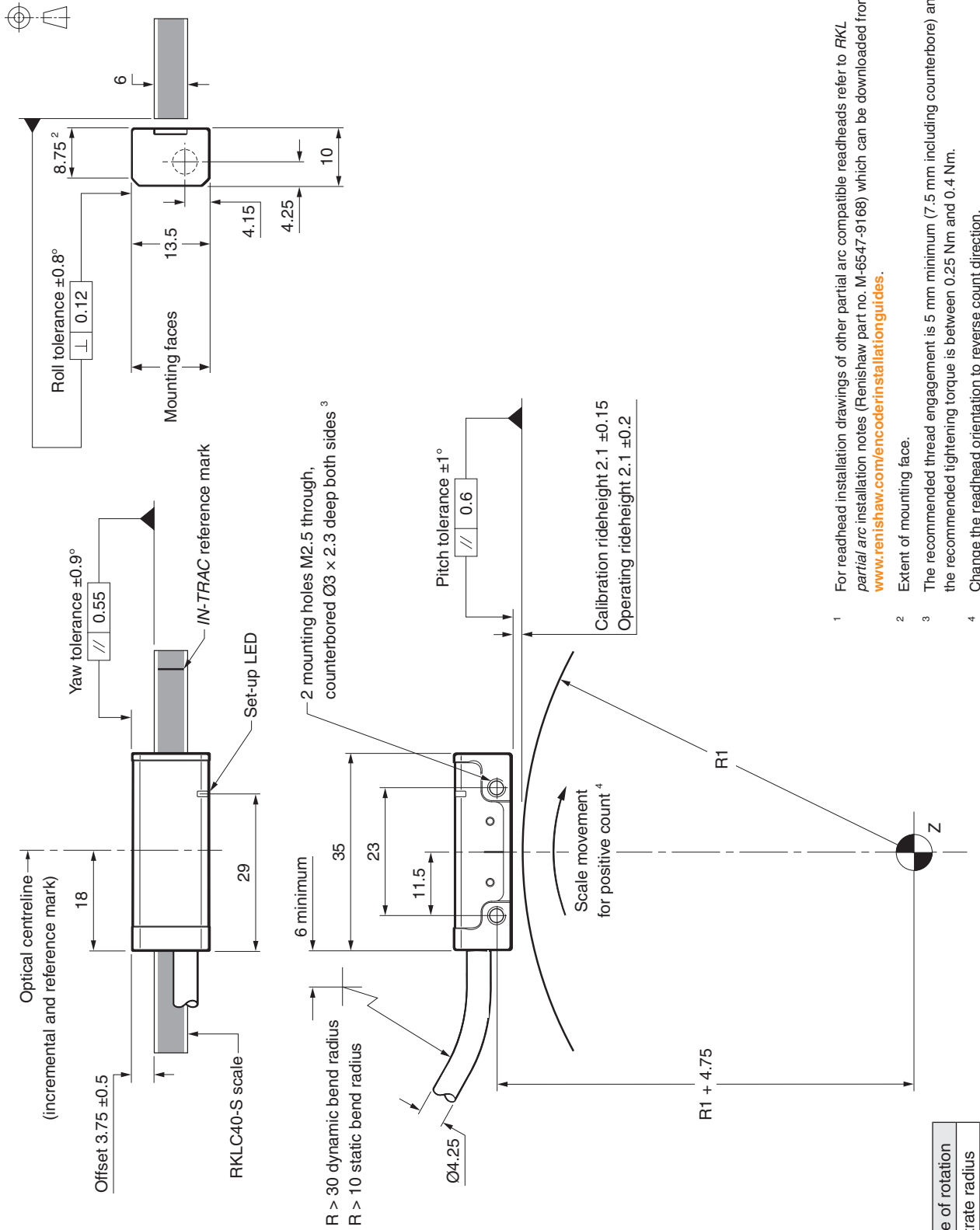

- ¹ For readhead installation drawings of other partial arc compatible readheads refer to *RKL partial arc* installation notes (Renishaw part no. M-6547-9168) which can be downloaded from www.renishaw.com/encoder/installationguides.
- ² Extent of mounting face.
- ³ The recommended thread engagement is 5 mm minimum (7.5 mm including counterbore) and the recommended tightening torque is between 0.25 Nm and 0.4 Nm.
- ⁴ Change the readhead orientation to reverse count direction.

Scale part numbers

Scale type	Part number (where xxxx is the scale length in cm) ¹	Available lengths	Compatible readheads
RKLC40-S	A-6665-xxxx	20 mm to 20 m (> 20 m available on request)	QUANTiC
RKLC20-S	A-6663-xxxx	20 mm to 20 m (> 20 m available on request)	VIONiC and TONiC
RKLF40-S	A-6769-xxxx	20 mm to 20 m (> 20 m available on request)	ATOM and ATOM DX ²
RKLA30-S	A-6667-xxxx	20 mm to 21 m	RESOLUTE

¹ For example, ordering A-6663-0110 will result in a 110 cm length of RKLC20-S.



² 40 µm ATOM and ATOM DX readhead variants only.

Accessory part numbers

RKL scale accessories

Part description	Part number	Product image
Guillotine (for cutting RKL scale)	A-9589-0071	
Shears (for cutting RKL scale)	A-9589-0133	
RKLC-S side mount scale applicator (compatible with VIONiC, TONiC and QUANTiC side mount systems)	A-6547-1912	
RKLC-S top mount scale applicator (required for TONiC top mounted systems only)	A-6547-1915	
RKLF-S side mount applicator (compatible with ATOM and ATOM DX)	A-6547-1943	
RKLF-S top mount applicator (compatible with ATOM and ATOM DX)	A-6547-1939	
RKLF-S slim side mount applicator (compatible with ATOM and ATOM DX)	A-6547-1947	
RKLA-S scale applicator (compatible with RESOLUTE)	A-6547-1918	

End clamp accessories

Part description	Part number	Product image
RGC-F end clamp kit - epoxy mounted (the RGC-F end clamps fix the ends of the partial arc scale to the substrate material)	A-9523-4015	
RGG-2 two part epoxy (the RGG-2 epoxy is recommended for the mounting of end clamps and scale ends)	A-9531-0342	

Reference mark accessories

Part description	Part number	Product image
Reference mark de-selector stickers (pack of 20 de-selector stickers - RKLf ATOM /ATOM DX systems only)	A-9402-0049	

www.renishaw.com/contact



#renishaw

+44 (0) 1453 524524

 uk@renishaw.com

© 2019–2023 Renishaw plc. All rights reserved. This document may not be copied or reproduced in whole or in part, or transferred to any other media or language by any means, without the prior written permission of Renishaw.

RENISHAW® and the probe symbol are registered trade marks of Renishaw plc. Renishaw product names, designations and the mark 'apply innovation' are trade marks of Renishaw plc or its subsidiaries. Other brand, product or company names are trade marks of their respective owners.

WHILE CONSIDERABLE EFFORT WAS MADE TO VERIFY THE ACCURACY OF THIS DOCUMENT AT PUBLICATION, ALL WARRANTIES, CONDITIONS, REPRESENTATIONS AND LIABILITY, HOWSOEVER ARISING, ARE EXCLUDED TO THE EXTENT PERMITTED BY LAW. RENISHAW RESERVES THE RIGHT TO MAKE CHANGES TO THIS DOCUMENT AND TO THE EQUIPMENT, AND/OR SOFTWARE AND THE SPECIFICATION DESCRIBED HEREIN WITHOUT OBLIGATION TO PROVIDE NOTICE OF SUCH CHANGES.

Renishaw plc. Registered in England and Wales. Company no: 1106260. Registered office: New Mills, Wotton-under-Edge, Glos, GL12 8JR, UK.

Part no.: L-9517-9897-02-A

Issued: 08.2023

Advanced Diagnostic Tool ADTi-100

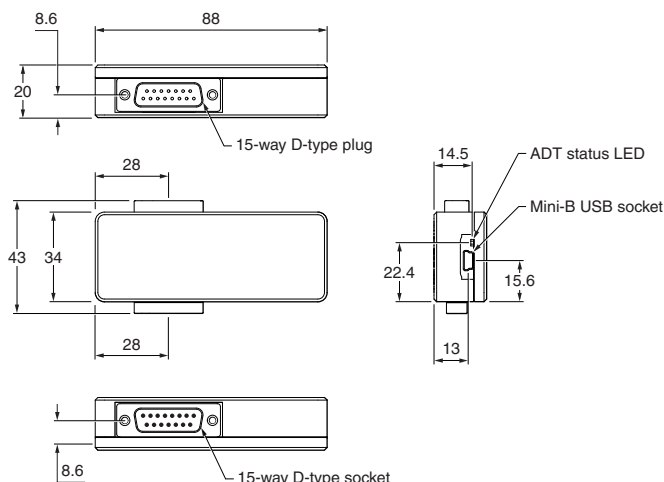

The ADTi-100 (A-6195-0100) is used in conjunction with a PC* running the ADT View software†.

It provides comprehensive real-time feedback from QUANTiC™, VIONiC™ and ATOM DX™ encoders, aiding installation and diagnostics, as well as allowing system optimisation.

Function	Signal	Encoder input/output 15-way D-type	
Power	5 V	7, 8	
	0 V	2, 9	
Incremental	A	+	14
		-	6
	B	+	13
		-	5
Reference mark	Z	+	12
		-	4
Limits‡	P	11	
	Q	10	
Alarm	E	-	3
Remote CAL‡	CAL		1
Shield	-		Case

‡ On input connector only.

‡ Limits not available with ATOM DX.

General specifications

Power supply	5V -5%/+10%	Typically 200 mA fully terminated (ADTi-100 and readhead)
		Power from a 5 V dc supply complying with the requirements for SELV of standard IEC 60950-1 or via PC's USB port
	Ripple	200 mVpp maximum @ frequency up to 500 kHz
Temperature	Storage	-20 °C to +70 °C
	Operating	0 °C to +55 °C
Humidity		95% relative humidity (non-condensing) to IEC 60068-2-78
Sealing		IP20
Shock	Operating	500 m/s ² , 11 ms, ½ sine, 3 axes
Vibration	Operating	40 m/s ² max @ 55 Hz to 2000 Hz
Mass		110 g
EMC compliance		IEC 61326-1: 2013

* Supported Windows® operating systems (x86 or x64): 7 SP1, 10.

† Free ADT View software download is available directly from www.renishaw.com/adt.

ADT and accessory part numbers

Part description	Part number	Product image
ADTi-100	A-6195-0100	
USB cable (ADTi-100 to PC)	A-9572-0098	
ADT View software	Free to download from www.renishaw.com/adt	

Adaptor cables

Adaptor cables enable readheads with different terminations to be connected to the 15-way D-type input of the ADTi-100. Consists of two cables. One from readhead cable to ADTi-100. The other, if required, from the ADTi-100 to the controller cable.

Digital readheads

Readhead cable termination*	Pin-out	Part number
D	15-way D-type (standard pin-out)	None required. Readhead plugs directly into ADTi-100.
A	9-way D-type	A-6195-0102
K	10-way JST	A-6195-2074
H	15-way D-type (alternative pin-out)	A-6195-0103
X	12-way circular	A-6195-0104
J	14-way JST	A-6195-2073

Analogue readheads

NOTE: The ADT will require 120 Ω termination. This must be provided by, either the controller, or the termination tool. Refer to *Advanced Diagnostic Tools and ADT View software User guide* (Renishaw part no. M-6195-9413) for more information.

Readhead cable termination*	Pin-out	Part number
L	15-way D-type (standard pin-out)	A-6637-1540
H	15-way D-type (alternative pin-out)	A-6195-0103
J	14-way JST	A-6195-2073

Part description	Product image	Part number
Termination tool (For use with analogue variant of QUANTiC)		A-6195-2132

* Determined from readhead nomenclature. Refer to relevant readhead series data sheet for full readhead nomenclatures.